

PROBABILITY OF IMMINENT FAILURE AS A ROUTING METRIC IN A HIGH-MOBILITY WIRELESS AD HOC NETWORK

Marco A. Alzate
Electronic Engineering Department
Universidad Distrital
Cra.7 No. 40-53, Bogotá, Colombia
malzate@udistrital.edu.co

John S. Baras
Electrical and Computer Engineering Department
University of Maryland at College Park
College Park, MD, 20742
baras@isr.umd.edu

ABSTRACT

The current duration of a link in a mobile wireless ad hoc network (MANET) has important information to offer with respect to its stability. Unlike location or signal strength methods, life measurements implicitly includes the effects of true propagation mechanisms, mobility space geometry, power control mechanisms and other phenomena that are ignored or simplistically modeled in the methods mentioned above. Consequently, the information contained in the current duration of the links can be used to enhance the accuracy of these methods. Furthermore, under high mobility conditions and in the absence of any resources for location and signal strength measurements, this information can also be used alone to obtain new routing metrics to enhance the performance of routing algorithms in a MANET. One such metric is the probability of imminent failure, which can also be used to predict route failures with relatively high accuracy. Here we modify DSR to use this metric, improving the efficiency by reducing the routing overhead.

Keywords: Wireless ad hoc networks, Routing metrics, Route stability, Link lifetime.

1. INTRODUCTION

Mobile ad hoc wireless networks (MANETs) are characterized by the absence of communication infrastructure and by the mobility of the hosts, which also act as routers [9]. Because of this, it is difficult to establish and maintain multihop routes, especially under high mobility, where frequent data flow disruptions and route reconstruction destroy the advantage of finding shortest or quickest routes [6, 10, 11]. So, under these conditions, an adequate optimality criterion is the stability of the route. In ABR [13], each node keeps track of the duration of the links with each of its current neighbors and advertises this longevity in the broadcast query packet. The route is chosen among those with links older than a given threshold, which are assumed to be stable. Here we verify that the stability varies widely with the age of the links, so the current duration of a link brings much more information than that given by a simple threshold. Furthermore, under high mobility conditions, most links are unstable and we cannot avoid using them without drastically reducing the connectivity. SSA [4] and RABR [1] are among the algorithms that use signal strength to

assess the stability of a link. These algorithms depend strongly on the propagation characteristics of the radio channels, since fading can produce large measurement fluctuations. Furthermore, nodes can adapt the transmit power to keep a certain degree of connectivity, in which case a constant signal strength does not necessarily implies stability.

Although geographic information has been used since long ago in protocols such as LAR [7] and DREAM [2], only recently it has been proposed to use this information to predict mobility and avoid data flow disruptions due to route failures [3, 12]. The information is obtained by an appropriate location service like GPS, which is being widely deployed. The link expiration time is easily obtained from current positions and velocities, assuming both that a bidirectional link exists between two nodes if they are closer than a given transmission range r , and that their velocities will not change during that time. In FORP [12], the routing metric is the minimum of the predicted route expiration times. Some disadvantages of this approach are the indoor unavailability of GPS location services, the dependence on a very simplistic propagation model, and the disregard of velocity changes.

[8] computes the probability of the existence of a link between two nodes T seconds in the future, given that currently such link exists. However, the probability is computed independently of whether or not the given link exists continuously during the next T seconds. [5] goes a step further considering the probability that the link will last, at least, T more seconds, but under the doubtful assumption that the time period during which a node moves with constant speed and direction is exponentially distributed with known parameter.

Here we propose a different approach that is not based on any assumption about the mobility or propagation models, nor the availability of any additional resources. The idea is to use the statistical information collected from measuring the duration of links, to estimate the probability that the link dies within the next Δt seconds (PIF -probability of imminent failure-) conditioned on the current age of the link. Next section shows the pertinence of current age to estimate the PIF of an existing link. Then we propose a new routing algorithm metric based on this estimation. The fourth section looks at the performance of the new metric. Finally we discuss the predictability of route failures before concluding the paper.

2. LINK'S PROBABILITY OF IMMINENT FAILURE

We evaluated the effect of the current age on PIF for many widely used mobility models. Our results, obtained previously and independently, were almost identical to those reported recently in [14]. Here we focus on a particular mobility model that seems to be slightly more realistic than the typical ones evaluated in [14]. This model consists of a U-shaped office building with $N (=47)$ offices in a $60 \times 48 \text{ m}^2$ area, as shown in figure 1. There are also N nodes so that, for each node, there is an associated home office where it stays most of the time. The nodes move from one office to another along the shortest path on the hallways, according to the following procedure:

- Each node stays at its home office during T_H seconds, where T_H is a random variable uniformly distributed in the range $[0, 2 t_h = 400 \text{ s}]$.
- Then chooses a destination office uniformly among the other $(N - 1)$ offices and moves to that destination using the shortest path along the hallways. The nodes move with a constant velocity $v=1 \text{ m/s}$, so the traveling time T_M only depends on the origin and destination offices.
- The node stays visiting this office during T_V seconds, where T_V is a random variable uniformly distributed in the range $[0, 2 t_v = 100 \text{ s}]$.
- Then the node returns home with probability $p_{rh} (=0.9)$, in which case it takes another traveling time T_M to get home and the whole procedure is repeated from the first step. Otherwise, with probability $1 - p_{rh}$, the procedure is repeated from the second step.

A bidirectional link exists between two nodes n_1 and n_2 if they are closer than $r=10 \text{ m}$. If the home offices of n_1 and n_2 are at a distance r or less, we say that n_1 and n_2 are neighbor nodes.

This is an interesting model because of several features likely found on real environments. For example, some regions are less populated than others. Some hallways are highly used by nodes in transit, while some others are seldom used. The movements have drastic turns with well-defined minimum and maximum times between turns, given by the geometry of the mobility plane. The U-shape introduces a natural obstacle that must be surmounted by multiple hop routes. The link life statistics depend on the particular pair of nodes: some of them become closely associated neighbors while some others will meet only sporadically. Indeed, there are only 87 pairs of neighbor nodes out of 1081 possible pairs, as shown in figure 2. We get a fairly connected network, although we also have several periods of network fragmentation to challenge the routing algorithms.

During an extensive simulation study, we check the existence of a link between each pair of nodes and register $N_i(t) =$ number of links between the i^{th} pair of nodes that lived t seconds, for $i=1,2,\dots,N(N-1)/2$ and $t \in N$. With these measures we compute $p_i(t) =$ fraction of links that

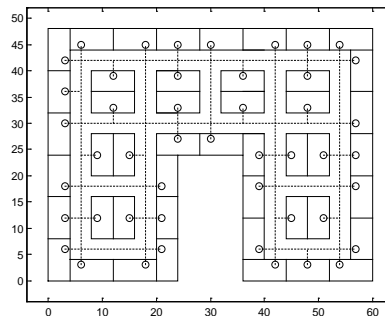

Figure 1. Mobility plane in our mobility model

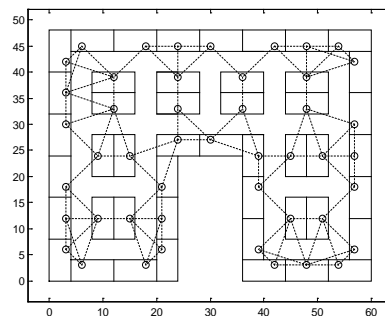

Figure 2. Neighbor nodes at home offices

lived t seconds, and $pif_i(t) =$ fraction of links that lived less than $t+5$ seconds among those that lived t or more seconds.

Figure 3 shows the pdf, $p_i(t)$, for the duration of the links between four pair of nodes (the most and least associated pair of neighbor nodes -those with the longest and shortest living links-, and the most and least associated pair of non-neighbor nodes). The first 27 seconds constitute a risky period during which 76% of the links dies (79% of links between non-neighbor nodes and 38% of links between neighbor nodes -only 7% of the links occur between neighbor nodes-). This is easily explained by looking at the geometry of the neighborhood of an office, shown in figure 4, which determines a set of most probable link durations. The time it takes to a moving node to traverse the transmission cell of a pausing node at any office is not longer than 27 seconds. If a link lives longer, either the corresponding nodes have been moving together or have been in simultaneous pause, in which case we say it is a stable link. Having that many unstable links dying at less than 27 seconds of age, it is highly likely that multihop routes must use some of these links. Consequently, short living links are the ones that determine the longevity of multihop routes. In the following sections we will take statistics only during the first 40 seconds of the life of a link. This will make our metrics independent of the distribution of the duration of the pauses. Figure 5 shows $pif_i(t)$ for the same four pair of nodes. The critical period can have high peaks, even for some neighbor nodes. Once the link survives the critical period, it becomes stable but, again, some links become more stable than others, as shown in figure 6. Similar results were obtained with different parameters and pause

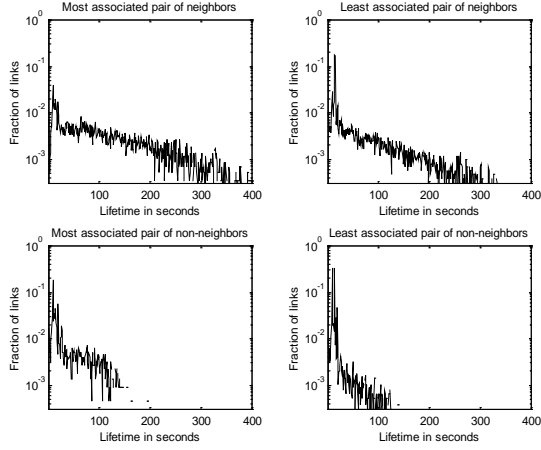

Figure 3. Probability that a link live t seconds

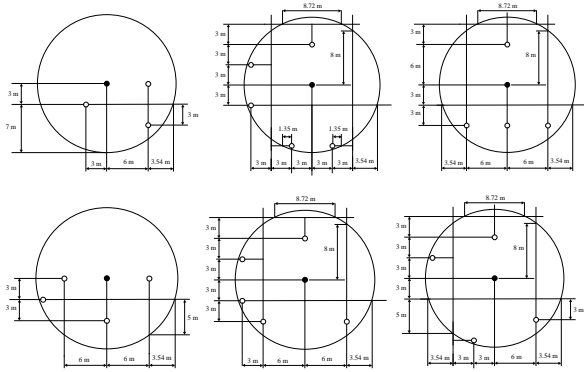

Figure 4. Neighborhoods of some offices

distributions of the mobility model, as well as with many different mobility models.

In conclusion, the current link duration contains a lot of information about how likely is the link to fail within the next Δt seconds. This information can be used in conjunction with geographic information (as in FORP) to enhance the accuracy of routing metrics and link expiration time predictions, and with signal strength information (as in SSA or RABR) to enhance the link stability assessment. However, here we assume the complete absence of location services and signal strength measurements, so we use exclusively the estimated link pif to obtain the route pif as a new routing metric.

3. PIF AS ROUTING METRIC

Consider a routing protocol in which each node measures the duration of the links with each other node and use these measurements to estimate the link pif , $p_{mn}(t) = \text{Prob}[T(m,n) \leq t + \Delta t \mid T(m,n) \geq t]$, where $T(m,n)$ is the duration of the current link between nodes m and n , which has existed for the last t seconds, and Δt is a parameter to be chosen. When a source node n_1 wants to send a packet to a destination for which there is not a known route, it broadcasts a *RouteRequest* packet containing a sequence number and the addresses of source and destination nodes. A neighbor node n_2 that listens the request, broadcasts it

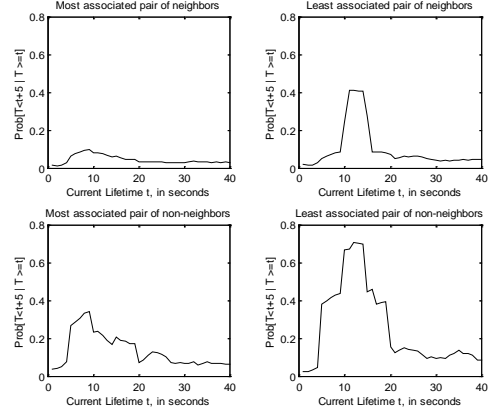

Figure 5. Probability of imminent failure

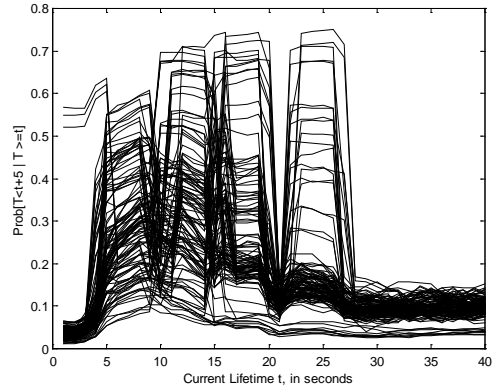

Figure 6. Superposition of several pif s

further after appending both its address (to construct an advertised source route) and a field P containing the estimated probability $p_{n_1, n_2}(t)$ that the corresponding link between nodes n_1 and n_2 dies within the next Δt seconds. Any subsequent intermediate node n_i that broadcasts the request further will append its own address and will change the field P from its current value P_{old} to an updated value $P_{new} = 1 - (1 - P_{old})(1 - p_{ni-1, ni}(t))$. This way, the field P carries the estimated pif of the route from n_1 to n_i . If a node already sent a request with a given source address and sequence number, it will not forward any additional request with those same fields, unless the advertised probability of failure is a fraction α of the last forwarded request. The destination sends a *RouteReply* packet for each of the first NR *RouteRequest* packets it receives. Additional arriving requests are replied only if their value in the field P is within the NR smallest values already replied. With each incoming *RouteReply*, the source node learns an additional route to the destination, each one more stable but also slower than the previous one. The source keeps the best NR routes and discards the others. After a link failure, a *RouteError* packet is sent erasing the routes that traversed the broken link and the data flow on those routes are handed off to one (or several) of the remaining routes. If there is no any route left, a new route discovery process is initiated.

The above routing protocol, LLR, is identical to DSR, except that the route pif is used as routing metric and

multiple replies are allowed, so several paths can be established from the source to the destination. Notice that the order of arrival of the *RouteReply* packets brings an implicit classification of the corresponding routes according to their latency. Therefore, the source can decide to use the fastest route, the longest-living route, an intermediate route that is a trade-off between these two criteria, or can even disperse the traffic among several routes.

4. PERFORMANCE COMPARISON

In an extensive simulation study, we applied both pure DSR and LLR with $\Delta t=5$. To be fair, in DSR we also allowed the destination to reply to the first *NR RouteRequest* packets it receives, which are the *NR* best routes under DSR criterion. We considered *NR* in the range $\{1,2,3,4,5,10,20\}$ and, in each case, α varies in the set $\{0, 0.25, 0.5, 0.75, 1\}$ (α -LLR algorithm).

Figure 7 shows the number of *RouteRequest* packets locally broadcasted for each route discovery process. It decreases very slightly with *NR*, but increases notoriously with α . In effect, $\alpha=0$ implies that intermediate nodes will forward only one copy of a given *RouteRequest* packet but, as α approaches one, we are allowing intermediate nodes to be more talkative and forward several copies of the same *RouteRequest* packet, generating additional overhead traffic for each route discovery process. However this is largely compensated with the bigger reduction in the number of route discovery processes initiated by the source node, as shown in figure 8. While pure DSR invoked this process once every 6.2 seconds in the average, 1-LLR reduced it to once every 10.6 s. The net effect, as shown in figure 9, is that we not only reduced the number of disruptions but also increased the efficiency on the use of the radio channels.

Similar results were obtained for other pause distributions and averages. With respect to the efficiency in the use of the radio channels, the distribution function itself is not as important as the mean pause duration.

5. FAILURE PREDICTION

A potential benefit of using the *pif* as a metric is the prediction of route failures (a route failure occurs when all known routes are broken). The idea is to raise an alarm within Δt seconds before route failure so that higher-level protocols have time to decide on an appropriate action. With this purpose, the source node computes the *pif* of the whole set of routes, $p(t) = \Pr[T(t) \leq t-t_0+\Delta t \mid T(t) \geq t-t_0]$, where t is the time index, $T(t)$ is the duration of the ON period active at time t (an ON period is a time interval during which at least one known route is in good state), and t_0 is the birth instant of that ON period. This *pif* of the whole set of routes is computed from the estimated probabilities of imminent failure of the links forming each route, which can be advertised within the source route on each packet. A simple prediction algorithm would detect

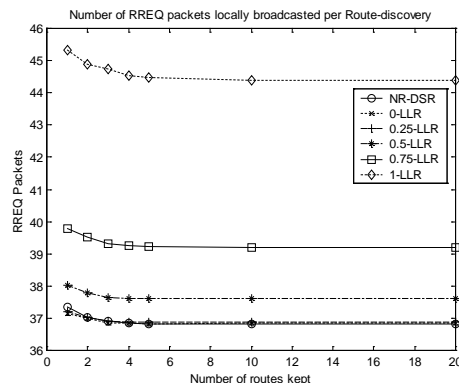

Figure 7. RREQ packets per route discovery

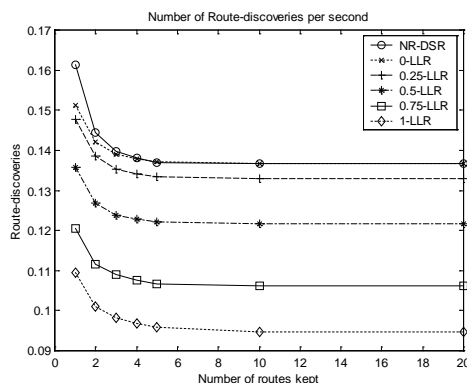

Figure 8. Route discoveries per second

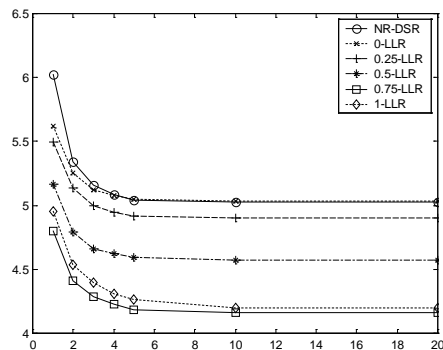

Figure 9. RREQ packets per second

when $p(t)$ exceeds a given threshold, in which case the source assumes that the current ON period will be finished within the next Δt seconds. We can also exploit some other easily measured concomitant variables. To obtain the maximum information about the true alarm condition, each variable is quantized so as to maximize its mutual information with the true alarm. The certainties of each measure are then combined to obtain a better estimation of $p_A(t)$ = Probability that the current ON period will finish within the next 5 seconds. A simple threshold is used on $p_A(t)$ to optimize an appropriate performance measure. In our simulations, we were right 86% of the time and detected opportunely 74% of the failures. The goodness of these results would depend on the application. As an example, for a transport layer mechanism, the high rate of correct predictions can be used as an additional valuable

information for its windowed flow control mechanism. An obvious network layer use is to try to prevent disruptions by initiating a new route discovery process with every alarm trigger. We reduced the number of disruptions to 65%, but also increased the number of route discoveries in 18%.

6. CONCLUSIONS

In mobile ad hoc wireless networks, the current age of a link has important information to offer about its own remaining duration. This information could be used to enhance the accuracy of link stability estimation methods based on geographic and signal strength information. Even in the absence of location services or power measurements, the current age of links can be used alone to obtain an estimate of the probability of imminent route failure. Under highly dynamic mobility conditions, this estimation can be used as a routing metric to reduce the number of disruptions due to route failures. In particular, we compare DSR with a modified version, LLR, using this new metric. Although each individual route discovery process requires the transmission of more routing packets with LLR than with DSR, the decrease in the number of disruptions compensate for this disadvantage, increasing the efficiency of LLR over DSR. Similar experiments with variations in the mean and pdf of the pauses show that, as the mobility reduces, so does the performance enhancement.

A side benefit of using the *pif* as a metric is the prediction of route failures. We obtained a high accuracy deciding whether the current set of routes is under imminent failure or not by selecting multiple thresholds on different concomitant easily measured variables, in such a way as to maximize the total information revealed about the condition of an imminent failure.

References

- [1] S. Agarwal, A. Ahija, J. P. Singh, and R. Shorey. Routelifetime Assessment Based Routing (RABR) Protocol for Mobile Ad-hoc Networks. In Proc. IEEE International Conference on Communications 2000 (ICC'00), volume 3.
- [2] S. Basagni, I. Chlamtac, V. Syrotiuk, and V. Woodward, "A Distance Routing Effect Algorithm for Mobility (DREAM)", Proceedings of the IEEE/ACM MOBICOMM'98, pp 76-84.
- [3] K. Chen, S. Shah and K. Nahrstedt "Cross-Layer Design for Data Accessibility in Mobile Ad Hoc Networks", Journal of Wireless Personal Communications, Kluwer Academic Publishers, Vol. 21, 2002.
- [4] R. Dube, C. Rais, K. Wang and S. Tripathi. "Signal Stability-Based Adaptive Routing (SSA) for Ad Hoc Mobile Networks", IEEE Personal Communications, 4(1):36-45, February 1997.
- [5] S. Jiang, D. He, and J. Rao. A Prediction-based Link Availability Estimation for Mobile Ad Hoc Networks. Proc. INFOCOM' 2001
- [6] D. Johnson and D. Maltz, "Dynamic Source Routing in Ad Hoc Wireless Networks". In "Mobile Computing", edited by T. Imielinsky and H. Korth, Kluwer, 1996.
- [7] Y. Ko and N. Vaidya, "Location Aided Routing (LAR) in Mobile Ad Hoc Networks", Proceedings of the IEEE/ACM MOBICOMM'98, pp 66-75.
- [8] A.B. McDonald and T. Znati, "A Path Availability Model for Wireless Ad-Hoc Networks", In Proceedings of the IEEE Wireless Communications and Networking Conference, 1999
- [9] C. Perkins (editor). Ad Hoc Networking. Addison Wesley, 2001
- [10] C. Perkins and P. Bhagwat. "DSDV: Routing over a Multihop Wireless Network of Mobile Computers". In "Mobile Computing", edited by T. Imielinsky and H. Korth, Kluwer, 1996.
- [11] C. Perkins and E. Royer. "Ad Hoc On-Demand Distance Vector Routing". Proc. 2nd IEEE Workshop on Mobile Computing Systems and Applications, 1999.
- [12] W. Su, S. Lee and M. Gerla "Mobility Prediction and Routing in Ad Hoc Wireless Networks", International Journal of Network Management 2001; 11:3-30.
- [13] C. Toh. "Associativity-Based Routing for Ad Hoc Wireless Networks" Journal on Wireless Personal Communications, Vol. 4, N. 2, 1997.
- [14] Michael Gerharz, Christian de Waal, Matthias Frank and Peter Martini. "Link Stability in Mobile Wireless Ad Hoc Networks", Proc. of the IEEE Conference on Local Computer Networks (LCN) 2002, Tampa, Florida, November 2002.