

**DEVICES – Ph.D. Qualifying Exam Spring 2005**

1. (10 pts) The characteristic, (i.e. drain-source current,  $I_{DS}$ ) of an ideal MOSFET in saturation as a function of gate source voltage,  $V_{GS}$  and threshold voltage,  $V_T$  (which depends on various transistor parameters), is

$$I_{DS} = (K/2)(V_{GS} - V_T)^2 \text{ where } K = (W/L)\mu_e(\epsilon_{ox}/t_{ox})$$

where  $\mu_e$  is the electron mobility,  $\epsilon_{ox}$  is the dielectric constant of the oxide.

Suppose you have an nMOS transistor whose gate oxide thickness,  $t_{ox}$ , changes from  $t_1$  to  $t_2$  in the middle of the channel width as shown in the figure below.

- a) How would you expect this transistor to behave. In particular, how would the plot of  $\sqrt{I_{DS}}$  vs.  $V_{GS}$  at constant  $V_{DS}$  (in saturation) look? Identify key features.
- b) Given the saturation characteristics of an ideal MOSFET given above, write down an expression for  $I_{DS}$  (in saturation) for the nMOS transistor shown.

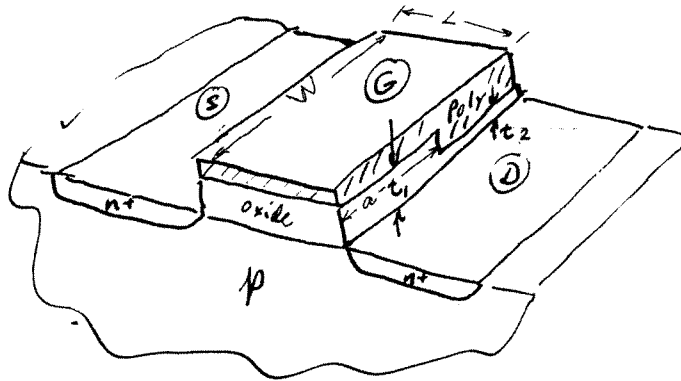

2. (10 pts) Consider a conventional bipolar transistor (i.e. an emitter, base, collector tri-layer sandwich). You want the transistor to have "good" useful characteristics, for example high beta.

- a) Why would you want the emitter to be more heavily doped than the base?
- b) Why do you want the base width (distance between emitter and collector) to be small?
- c) Why do you want the collector to be lightly doped compared to the base? (There are two reasons.